

The operating instructions can be found at www.a-eberle.de



Installation guidelines

Power Quality Analyser

Model: PQI-DA *smart*

- ▶ Fitting
- ▶ Initial commissioning

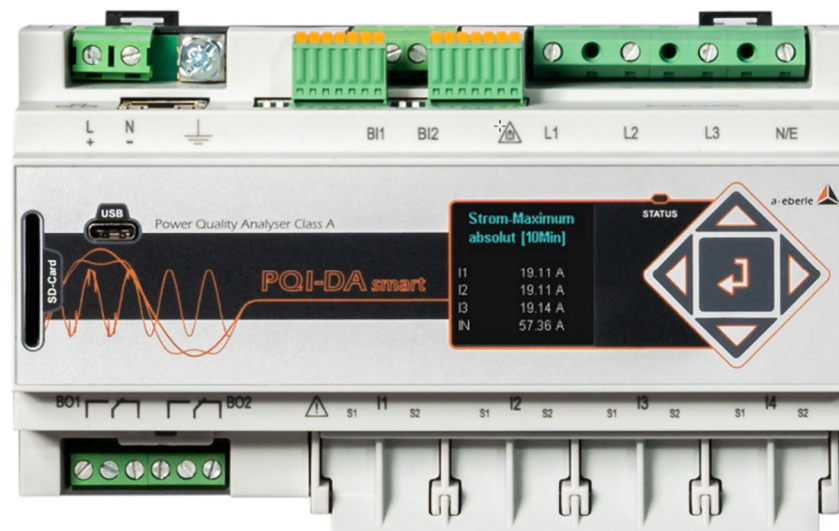

A. Eberle GmbH & Co. KG

Frankenstraße 160
D-90461 Nürnberg

Telefon: 0911 / 62 81 08 0
Telefax: 0911 / 62 81 08 99
E-Mail: info@a-eberle.de
Internet: www.a-eberle.de

1. Notes

1.1 General information

These installation instructions contain all-important information for mounting and commissioning. Read the manual carefully and completely, it contains important information about the product. Observe the notes and follow the safety and warning instructions in particular. Keep the manual carefully and ensure that it is always available and can be viewed by the user of the product.

The company **A. Eberle GmbH & Co. KG** does not accept any liability for damage or loss of any kind resulting from failure to observe the product information or resulting from printing errors or changes in this installation guidelines. The company **A. Eberle GmbH & Co. KG** does not accept any liability for damage or loss of any kind resulting from faulty devices or from devices that have been modified by the user.

1.2 Revisions

Please note that these installation instructions may not always represent the most up-to-date information on the device. If, for example, you have changed the firmware of the device in the direction of a later firmware version, the present installation instructions may no longer be suitable in every point.

In this case, either contact us directly or use the latest version of the installation instructions available on our website (www.a-eberle.de) and the other documents available for the device.

Copyright 2020 A. Eberle GmbH & Co. KG

Subject to change without notice

1.3 Disposal

The disposal of the device is handled by A. Eberle GmbH & Co. KG.

Send all components to A. Eberle:

A. Eberle GmbH & Co. KG
Frankenstraße 160
D-90461 Nuremberg



1.4 Warranty

A. Eberle warrants this product and accessories to be free from defects in materials and workmanship for a period of three years from the date of purchase.

Warranty does not apply to damage caused by:

- Accidents
- Misuse
- Abnormal operating conditions.

To claim warranty, contact A. Eberle GmbH & Co KG in Nuremberg, Germany or use the RMA form on the homepage at www.a-eberle.de.

2. Safety

2.1 Safety Instructions

IT IS IMPORTANT FOR PERSONAL SAFETY TO FOLLOW THESE INSTRUCTIONS. THESE INSTRUCTIONS MUST BE KEPT IN A SAFE PLACE!

- Observe operating instructions.
- Always keep the operating instructions with the appliance.
- Ensure that the machine is only operated in perfect condition.
- Never open the device.
- Ensure that only qualified personnel operate the device.
- Only connect the device according to instructions.
- Ensure that the device is only operated in its original condition.
- Only operate the device with recommended accessories.
- Ensure that the device is not operated above its rated data (see technical data in chapter 5)
- Ensure that the original accessories are not operated above the rated data.
- Do not operate the device in environments where explosive gases, dust or vapours are present.

The installation instructions do not represent a complete list of all safety instructions necessary for the operation of the device. Special operating conditions may require further instructions. The installation instructions contain information that you must observe for your personal safety and to prevent damage to property.





2.2 Structure of the warnings

Warnings are structured as follows:

 SIGNAL WORD	<p>Nature and source of the danger!</p> <p>Consequences if not observed.</p> <ul style="list-style-type: none"> ➤ Steps to avoid the danger.
--	--

2.3 Graduation of warnings

Warnings differ according to the type of danger as follows:

 DANGER!	Warns of an imminent danger which, if not avoided, will result in death or serious injury.
 WARNING!	Warns of a potentially dangerous situation that can result in death or serious injuries when not avoided.
 CAUTION!	Warns of a potentially dangerous situation that can result in fairly serious or minor injuries when not avoided.
NOTICE!	Warns of a potentially dangerous situation that if not avoided could result in material or environmental damage.
	Refers to processes where there is no risk of injury or damage to property, but which must be observed for reliable operation of the device!

2.4 Intended use

The product is designed exclusively for the measurement and evaluation of voltage and current signals in the energy network. If the measuring device is used in a way which is not specified by the manufacturer, the protection supported by the device can be severely limited. The device is intended for use for measurement in the low voltage range in CAT IV (300 V) up to a maximum of 690 V (conductor/conductor). Other voltage levels such as medium- or high-voltages must be connected to the instrument via voltage transformers. All technical connection values and rated data must be observed!

The PQI-DA *smart* is suitable for the following installation location and should, should only be operated in this environment

- Mounting in a control cabinet and compact distribution board
- Panel mounting with mounting frame (Article: 564.0435)

2.5 Other applicable

For the safe and correct use of the device, please also observe the other documents such as the complete operating instructions and the additional documents supplied, as well as the relevant standards and laws.

2.6 Target group

These installation instructions are intended for trained specialist staff as well as trained and tested operating personnel. The contents of these installation instructions must be made available to the persons entrusted with the installation and operation of the system. In order to avoid damage to property and personal injury, the qualified personnel must be trained electro technically and have the following knowledge

- Knowledge of national accident prevention regulations
- Knowledge of safety engineering standards
- Knowledge of installation, commissioning and operation

2.7 Cleaning

Use a soft, slightly moistened and lint-free towel. Make sure that no moisture penetrates the housing. Do not use window cleaners, household cleaners, sprays, solvents, cleaners containing alcohol, ammonia solutions or scouring agents for cleaning. Please use only water for cleaning.

2.8 Meaning of the symbols used on the device



Nature and source of the danger! Read the safety instructions inside the manual!

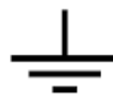

Functional earth of the measuring device



USB-interface



TCP-IP interface



CE marking guarantees compliance with the European directives and regulations regarding Electromagnetic Compatibility (EMC)



Alternating voltage (AC)



Direct voltage (DC)

3. Commissioning

3.1 PQI-DA smart Summary description

The Power Quality Analyser and Fault Recorder PQI-DA *smart* for low, medium and high voltage networks is the central component of a system with which all measurement tasks in electrical networks can be solved.

The PQI-DA *smart* can be used as a Power Quality Interface according to power quality standards such as IEC61000-2-2 / EN50160 or to check the technical connection guidelines such as DIN VDE AR 4110 and DIN VDE 4120 and many more. Due to the available SCADA interfaces such as Modbus RTU/TCP as well as IEC 61850, the device can also be used as a highly accurate measurement transducer for all physically defined measured variables in 3-phase systems parallel to the continuous recording of measured values over a very long period.

In addition to the possibility of standard evaluations, the PQI-DA *smart* also has a high-speed disturbance recorder with a recording rate of 40.96 kHz/10.24 kHz and a 10ms TRMS effective value recorder. This allows a detailed evaluation of grid disturbances.

3.1 Scope of Delivery

- PQI-DA *smart*
- Installations guidelines
- Ethernet cable
- Calibration certificate
- CD WinPQ lite Software incl. user manual

3.2 Fitting

The PQI-DA *smart* is suitable for the following installation location and should only be operated in this environment

- Mounting in a control cabinet and small distribution board
- Panel mounting with mounting frame (Article: 564.0435)

The PQI-DA *smarts* can be installed in any position of use by snap-on mounting with three mounting elements on a 35 mm wide top-hat rail to EN60715. For mounting, the device is guided at an angle to the top-hat rail from above and snapped in at the bottom. The lower mounting element audibly snaps into place behind the top-hat rail.

The device can be removed from the top-hat rail with the aid of a screwdriver by pulling out the lower fastening element.

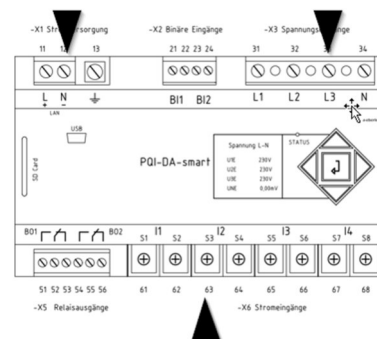

Position of the mounting elements

NOTICE!

Material damage due to non-observance of the installation instructions!

Non-observance of the installation instructions or incorrect installation can damage the device!

- ➡ Pay attention to the audible snapping of the mounting elements

3.3 Functional earth

The device is provided with a functional earth, which also serves as reference potential for the voltage inputs.

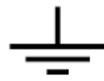

The functional earth is marked with  and terminal X1 / 13 on the measuring instrument.

Connect the grounding cable to terminal X1 / 13 on the meter and tighten the screw. Use an eyelet terminal for the connection and make sure it is tight!

⚠ DANGER! Danger to life due to electric shock!

Incorrect connection of this measuring instrument can lead to death, serious injury or fire hazard!

- ➡ The functional earth must always be connected to PE potential.
- ➡ The functional earth must not carry a dangerous voltage under any circumstances

3.4 Supply voltage

The PQI-DA *smart* is available with two different supply voltage characteristics. Please take the correct supply voltage from the type label before connection.

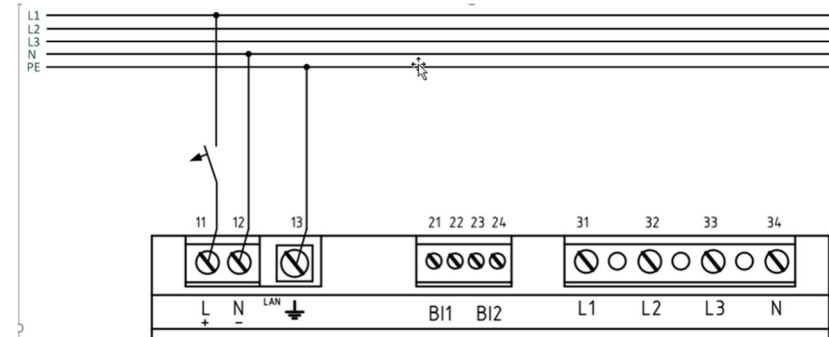

Example of connection to 230V AC with feature

After connecting and switching on the power supply, the status LED lights up red, changes to green and the display starts the commissioning assistant.

⚠ DANGER! Danger to life due to electric shock!

Serious personal injury or death may result from:

- Touching bare or stripped wires that are energised.
- Touching dangerous inputs on the device.
- ➡ Make sure that the device is connected in a de-energized state.
- ➡ Ensure that all connecting cables are fixed and strain relief is provided.
- ➡ All cable requirements of the terminal blocks must be observed. (e.g. stripping length of the cables)

NOTICE!**Material damage due to non-observance of the connection conditions or impermissible overvoltage!**

Failure to comply with the connection conditions or exceeding the permissible voltage range may damage or destroy your device.

Before applying the supply voltage to the device, the following points must be observed:

- Voltage and frequency must correspond to the specifications on the type label! Observe the limit values as described in the technical data!
- Observe features of the device (H1 / H2)
- In the building installation, the supply voltage must be provided by a listed miniature circuit breaker and fuse that meets the requirements of IEC 60947-1 and IEC 60947-3!
- The miniature circuit breaker must
 - be easily accessible to the user and installed close to the device.
 - Label for the respective device.
- Do not take the supply voltage at the voltage transformers.
- Provide a fuse for the neutral conductor if the neutral connection of the source is not earthed.

3.5 Mains connection for PQI-DA *smart*

The mains connection of the PQI-DA *smart* depends on the type of mains in which the measurement is to be made.

The PQI-DA *smart* is designed for direct measurement in low voltage (3 phase / 4 wire connection) for low voltage networks (TN, TT and IT networks) or for residential and industrial applications.

A special form of low voltage measurement is the measurement 4-wire / 1 phase connection with which three independent voltage circuits and current circuits can be measured with the same ground conditions.

For medium and high voltage the device can be connected via suitable transformers. A connection with three voltage and current transformers is possible as well as the connection via transformer saving circuits (V-circuit, Aron circuit).

In addition, current measurements with small signal inputs are possible with the corresponding sensor transformers (hardware features C40, C44 and C45).

⚠ WARNING!**Personal injury and damage to property due to non-observance of the safety regulations**

- Before making any connections, please read this manual thoroughly and follow the safety measures described here.

3.5.1 3-phase / 4-wire connection

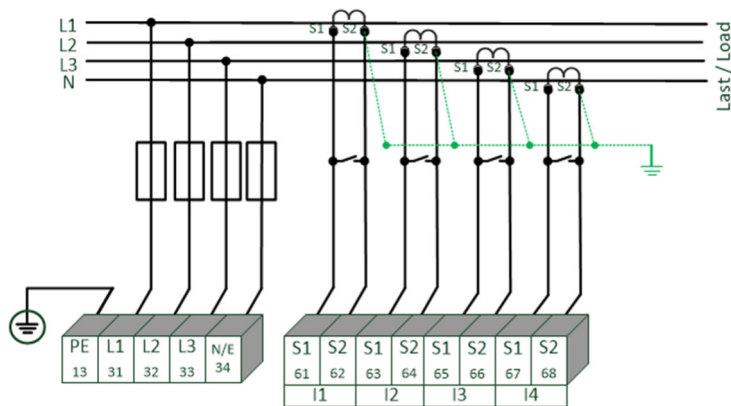

Example of a connection for a PQI-DA smart in a three-phase four-wire system

► Voltage connections

The voltage connections must be made as shown in the circuit diagram above

- If no N conductor connection is available, connect connections E and N together.
- Make sure that the switching mode (4-wire) is set (settings are described in chapter 4.3).

► Current connections

The PQI-DA smart is designed for measuring circuits (C30) or protection circuits (C31) depending on the characteristics.

The current transformer ratio is set at the factory to nominal current (e.g. 5 A) depending on the feature and must be adapted to the transformers used. With feature C30 / C31 only alternating currents, no DC currents can be measured. Furthermore features C40, C44 and C45 offer the possibility to connect Rogowski coils, mini current clamps and DC current clamps to the measuring instrument. This makes it possible to connect the measuring device without disconnecting the current transformer or consumer circuits. The corresponding converters can be obtained from A.Eberle. The connection of converters of other manufacturers is possible as long as the described connection conditions (input range, impedance) are observed.

⚠ DANGER!

Danger to life due to electric shock!

Attention dangerous contact voltage!

Flashover and high short-circuit currents possible in CAT III and CAT IV!

- ➡ Ensure that the PE conductor (earthing) is connected to the PQI-DA smart.
- ➡ Before starting work, check that no voltage is present!
- ➡ Provide protective equipment for CAT II, CAT III or CAT IV.
- ➡ High-load fuses >10 kA or >50 kA must be used in accordance with the CAT.
- ➡ Short-circuit current transformers before starting work.
- ➡ Ensure that all connecting cables are fixed and strain-relieved.
- ➡ All cable requirements of the terminal blocks must be observed (e.g. stripping length of the cables).

3.5.2 3-Phase / 4-wire connection without neutral current

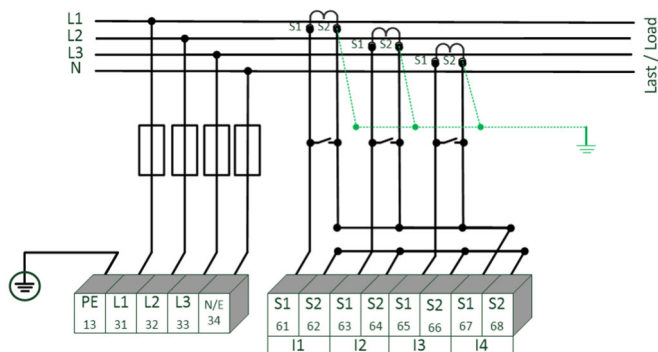

PQI-DA smart without neutral conductor of current transformer in 4-wire connection

► Voltage connections

- If no N conductor connection is available, connect connections E and N together.
- Make sure that the switching mode (4-wire) is set (settings are described in chapter 4.3).

► Current connections

- If no neutral conductor current is available in the 3-phase 4-wire network, the S2 current inputs of the PQI-DA smart must all be short-circuited and the S2 terminals of the current transformers used must be connected to S1 (terminal X6:67).
- The PQI-DA smart is designed for measuring circuits (C30) or protection circuits (C31) depending on the characteristics.

3.5.3 4-wire / 1-phase

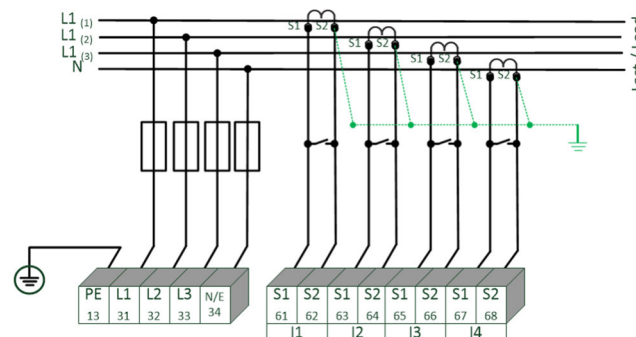

PQI-DA smart in 4-wire connection -1-phase

In the 4-wire network / 1-phase circuit type, no wire-conductor events and three-phase network events are evaluated. Voltages with the same earth potential can be connected (e.g. three networks with phase L1) and any currents can be connected.

⚠ DANGER! Danger to life due to electric shock!

Attention dangerous contact voltage!

Flashover and high short-circuit currents possible in CAT III and CAT IV!

- ➡ Ensure that the PE conductor (earthing) is connected to the PQI-DA smart.
- ➡ Before starting work, check that no voltage is present!
- ➡ Provide protective equipment for CAT II, CAT III or CAT IV.
- ➡ High-load fuses >10 kA or >50 kA must be used in accordance with the CAT.
- ➡ Short-circuit current transformers before starting work.
- ➡ Ensure that all connecting cables are fixed and strain-relieved.
- ➡ All cable requirements of the terminal blocks must be observed (e.g. stripping length of the cables).

3.5.4 3-phase / 3-wire connection

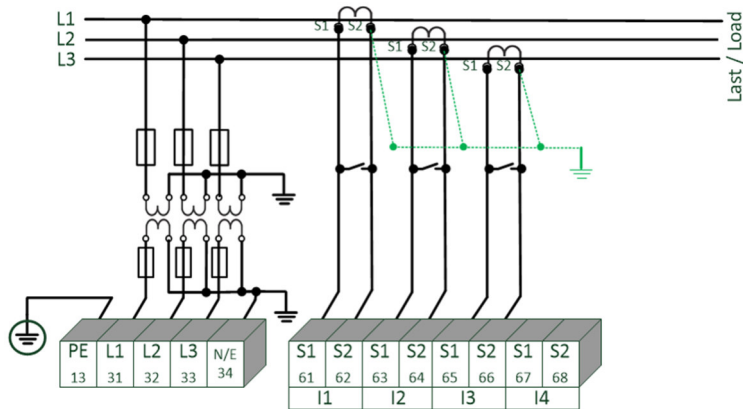

PQI-DA smart in 3-wire connection for medium and high-voltage via transformer

► Voltage connections

- Make sure that the measuring cable N/ E is connected to terminal 34 for each measurement. This is usually the earthing point of the voltage transformer.
- Ensure that the switching mode (3-wire) is set settings are described in chapter 4.3)
- Set the voltage transformation ratio
- Enter the nominal voltage of the conductor-conductor voltage.

► Current connections

- Set current transformer ratio.

Connection PQI-DA *smart* current I_N in 3-wire network



If a current is connected to input I_N in the 3-wire network, it is not physically measured. The current I_N is always calculated in 3-wire operation.

transducer settings



The transducer settings are set in the assistant in the chapter "Parametrization" (see user manual).

3.5.4.1 Aron / V circuit

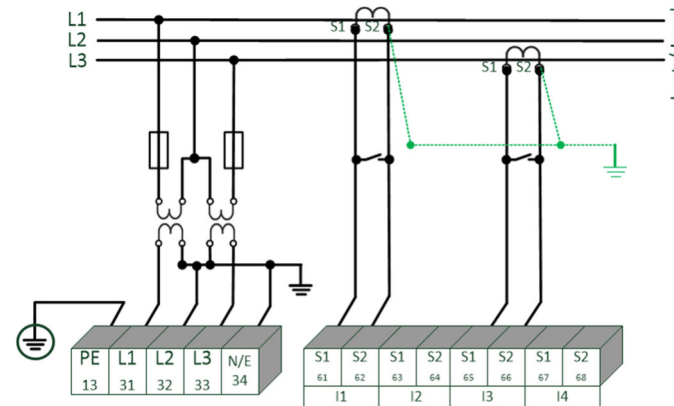

Information on the parameterization of the Aron / V circuit can be found in the user manual!



DANGER!

Danger to life due to electric shock!

Attention dangerous contact voltage!

Flashover and high short-circuit currents possible in CAT III and CAT IV!

- Ensure that the PE conductor (earthing) is connected to the PQI-DA *smart*.
- Before starting work, check that no voltage is present!
- Provide protective equipment for CAT II, CAT III or CAT IV.
- High-load fuses >10 kA or >50 kA must be used in accordance with the CAT.
- Short-circuit current transformers before starting work.
- Ensure that all connecting cables are fixed and strain-relieved.
- All cable requirements of the terminal blocks must be observed (e.g. stripping length of the cables).

3.5.5 Current sensor inputs– Feature C40 / C44 / C45

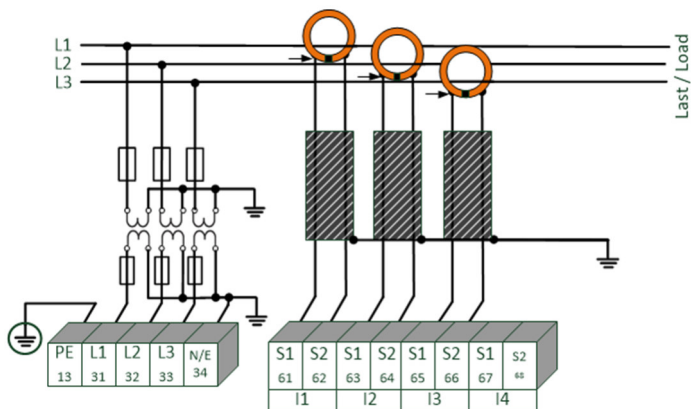

Example of PQI-DA smart connection with Rogowski coils in a 3-wire network

Connection PQI-DA smart sensor inputs

The shielding of the converters used must be earthed in order to minimize stray influences! In the case of permanently installed converters, the screen should also be earthed on the converter side if possible. If the ground potential difference between converter side and device is significant, the screen on the converter side can also be grounded capacitive (e.g. 1 μ F/250 V/X2).



► Feature C40: - Rogowski

The input is calibrated to 85mV/A. When using other transducer factors, the transducer factor ratio must be set correctly. The settings can easily be made during the initial commissioning (see chapter 4.3).

Parameterisation



Feature C40: The input is calibrated to 85mV/A. When using other converter factors, the converter factor ratio must be set correctly.

⚠ DANGER!

Danger to life due to electric shock!

Attention dangerous contact voltage!

Flashover and high short-circuit currents possible in CAT III and CAT IV!

- ➡ Ensure that the PE conductor (earthing) is connected to the PQI-DA *smart*.
- ➡ Before starting work, check that no voltage is present!
- ➡ Provide protective equipment for CAT II, CAT III or CAT IV.
- ➡ High-load fuses >10 kA or >50 kA must be used in accordance with the CAT.
- ➡ Short-circuit current transformers before starting work.
- ➡ Ensure that all connecting cables are fixed and strain-relieved.
- ➡ All cable requirements of the terminal blocks must be observed (e.g. stripping length of the cables).

⚠ WARNING!

Personal injury and damage to property due to non-observance of the safety regulations

The current small signal measuring inputs are symmetrical and not galvanically isolated from earth! The inputs offer no protective separation function with regard to electrical safety!

- ➡ The protection functions must be completely provided in the external converters.
- ➡ The converter outputs must be balanced and potential-free!

3.5.6 DC mains connection (Feature C44 / C45)

Using features C44 and C45 for current measurement, it is generally possible to use the PQI-DA smart in DC networks under the following conditions.

For DC voltage measurement, a difference must be made between symmetrically earthed and solidly earthed systems.

- For IT systems with high-impedance centre grounding, the device is designed for measurements up to ± 600 V, with more than ± 300 V an overvoltage protection is required to comply with the CAT III 600 V.
- For TN-S system, the device is designed for measurement up to 600 V.

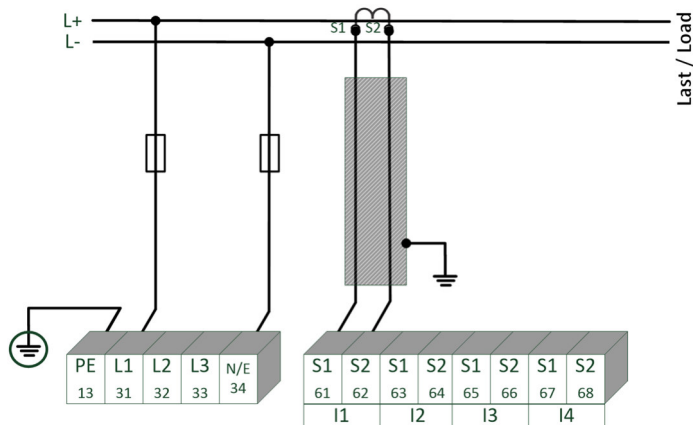

Example connection PQI-DA smart with current transformer with small signal output (e.g. 4 V)

Depending on the feature, the device is suitable for direct acting current transformers (e.g. open-loop Hall Effect current transformers) with an analogue output voltage up to ± 5.6 V (typically ± 4 V or ± 1 V). The measurable bandwidth on the device is DC...20 kHz. Shielding of the signal lines is recommended, but not absolutely necessary.

Parameter



The parameters 4-wire connection and 3-wire connection are valid for current measurement with C4X features as well as for C3X features.

⚠ DANGER!

Danger to life due to electric shock!

Attention dangerous contact voltage!

Flashover and high short-circuit currents possible in CAT III and CAT IV!

- ➡ Ensure that the PE conductor (earthing) is connected to the PQI-DA *smart*.
- ➡ Before starting work, check that no voltage is present!
- ➡ Provide protective equipment for CAT II, CAT III or CAT IV.
- ➡ High-load fuses >10 kA or >50 kA must be used in accordance with the CAT.
- ➡ Short-circuit current transformers before starting work.
- ➡ Ensure that all connecting cables are fixed and strain-relieved.
- ➡ All cable requirements of the terminal blocks must be observed (e.g. stripping length of the cables).

⚠ WARNING!

Personal injury and damage to property due to non-observance of the safety regulations

The current small signal measuring inputs are symmetrical and not galvanically isolated from earth! The inputs offer no protective separation function with regard to electrical safety!

- ➡ The protection functions must be completely provided in the external converters.
- ➡ The converter outputs must be balanced and potential-free!

4. Operation of the PQI-DA *smart*

4.1 Getting started

When the power analyser PQI-DA *smart* is put into operation for the first time, the instrument will appear in a guided "Wizard" mode. The operator is automatically guided through the initial commissioning of the instrument. This Wizard **must** be performed once after the PQ meter has been fully connected.



It is recommended to perform the wizard only after all wiring has been completed so that no incorrect measurement data is recorded due to the absence of measurement voltage, currents or parameters that have not been entered.



Since firmware version 2.0 the recording of the measurement data is only started after the complete completion of the wizard!

4.2 Initial Setup - Operation of the Assistant

The following actions can be performed using the navigation cross on the PQI-DA *smart*:

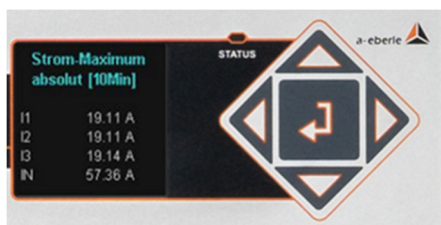

▶ **Arrow key right / down:**

Continue in wizard

▶ **Arrow key left / up:**

Back in wizard

▶ **Enter key :** 

Changing parameters

4.3 First commissioning - wizard - procedure

▶ **Wizard setting Language & PQ-Standard**

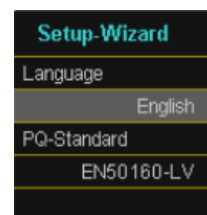

- Selection of display language PQI-DA *smart*
- Selection of the Power Quality standard
- **Low-voltage grid** => EN50160-LV
- **Medium-voltage grid** => EN50160-MV
- **High-voltage grid** => EN50160-HV

Automatic basic settings and limit values for the following voltage level according to EN50160.

The selection of the voltage level has an influence on which measures should be recorded, on the thresholds and also at the IEC61850 Interface which data can be used at IEC61850 Interface.

▶ **Wizard setting Net type & Net frequency**

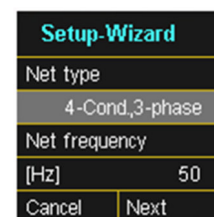

Basic settings / network connection PQI-DA *smart*



The net type form cannot be edited if the PQ standard EN50160-MV/HV is selected!

For more information about the network connection, see Chapter: 3.5 *Mains connection for PQI-DA smart*

● **Net Type:**

Entering the grid type "3-conductor grid", "4-conductor grid" and/or "4 x 1 conductor grid" will determine how the Power Quality events are recorded.

Switch between 3-conductor and 4-conductor grids.

- In a 3-conductor grid, all events are calculated from the conductor-conductor voltages.
- In a 4-conductor grid and/or a 4 x 1 conductor grid all Power Quality events are determined from the conductor - earth voltages.

● **Grid frequency:**

Setting grid frequency to 50 Hz or 60 Hz.

▶ Wizard setting Voltage Transformer

Voltage Transform.	
primary Voltage	
[V] P-P	20000
sec. Voltage	
[V] P-P	100.00

● Primary Voltage:

Corresponds to the primary rated voltage of the voltage transformer.

● Sec. Voltage:

Corresponds to the secondary rated voltage of the voltage transformer.



The voltage transformer factor is calculated automatically!



If Power Quality standard for low voltage network (EN50160-NS) is selected, the page voltage transformer is skipped, because the device can cover the complete range without transformer settings. Therefore, no input is necessary, as no voltage transformer factor has to be calculated.

▶ Wizard setting Current Transformer

Current Transform.	
primary Current	
[A]	3000
sec. Current	
[A]	5.0

● Primary Current:

Primary nominal current of the connected current transformer.

● Sec. Current:

Secondary nominal current of the connected current transformer.



The voltage transformer factor is calculated automatically!



The page is hidden for PQI-DA *smarts* with the features C40 (current inputs Rogowski) and C44/C45 (current inputs current clamps).

▶ Wizard setting System Load



The indicator on the system current page is hardware-specific and is automatically adapted to the PQI-DA *smart* that is to be commissioned.

Feature C30/C31

System Load	
Rated Current	
[A]	3000.0

● Rated Current:

Setting the nominal current of the system.

▶ Wizard setting Voltage Grid

Voltage Grid	
Reference Voltage	
[V] P-N	11547
[V] P-P	20000

● Reference voltage in low voltage

Setting the reference voltage in the low voltage as conductor-earth voltage in volts and in the medium or high voltage as conductor-conductor voltage in volts.



The non-editable parameters are calculated automatically.

Feature C40

System Load	
Rated Current	
[A]	3000.0
Trans.Fact.Equipm.	
[mV/A]	100

- **Rated Current:**

Setting the nominal current of the system.

- **Trans.Fact.Equipm.:**

Setting the transformer factor of Rogowski coils connected to the current input.

Feature C44/C45

System Load	
Rated Current	
[A]	3000.0
Trans.Fact.Equipm.	
[mV/A]	100

- **Rated Current:**

Setting the nominal current of the system.

- **Trans.Fact.Equipm.:**

Setting the transformer factor of current coils connected to the current input.

▶ **Wizard setting Date & Time**

Setup-Wizard	
Date	
	14.06.19
Time	
	09:22:22

Manual entry of date and time as local time (UTC+1)

Setup-Wizard	
Timezone	
	+01:00
DST	
	INT

- **Timezone:**

Setting of Timezone.

- **DST:**

Setting whether summer- and winter-time changeover should take place.



In the factory setting, the device is set to time zone UTC+1 with automatic winter time changeover. The time zone and summer/winter time changeover must be adapted to local conditions.

According to IEC61000-4-30, an external synchronization source such as NTP / DCF77 / GPS is required. The settings are described in the user manual.

▶ **Wizard setting Interface**

- **DHCP:**

DHCP deactivated: The device is used with a fixed IP address which have to be parameterized in the next step

DHCP activated: The device gets its IP-Address direct from a DHCP Server, which has to be reachable!



The IP address as well as the page with subnet masks and gateway is hidden when DHCP is active.

Setup-Wizard	
DHCP	
	Deactivated
IP address	
	192.168.56.95

- **IP address:**

Entry of a fixed IP address as specified by IT

- **Subnetmask:**

Entering the subnet mask

- **Gateway:**

Entering a gateway

Setup-Wizard	
Subnetmask	
	255.255.0.0
Gateway	
	192.168.0.1



In the factory setting, the PQI-DA *smart* is factory pre-set with the IP address 192.168.56.95 and the subnet mask 255.255.0.0.

▶ **Wizard setting Security mode (with Firmware >v2.0)**



● **Security Mode**

Active: high security mode

The device is set up in security mode. Communication is encrypted and device access is protected. The completion of the commissioning in security mode requires the setup of the necessary user accounts and must be completed with the software WinPQ or WinPQ lite with version 5.0 or higher. All details on encryption technology etc. are described in the security documentation.

Inactive compatible mode

The installation of devices in compatibility mode results in a non IT-secure operation of the measuring device, if no other measures for the encryption of the connection are available in the used network (e.g. VPN solutions with encryption / disconnected network or similar), because neither the communication between WinPQ software and the PQ device is encrypted nor the device access is protected. This mode is intended for compatibility with WinPQ systems smaller than version 5 and systems with WinPQ versions 5 or higher should be operated in high security mode.

 In any case, make a note of the serial number of your measuring instrument!

 When the SD card is inserted, an identification file with the required certificates for the recognition of the device is stored in the root directory of the SD card.

 The separate security documentation for administrators describes all security-relevant system settings for setting up and operating the device and the entire PQ system (requirement of the BDEW Whitepaper).

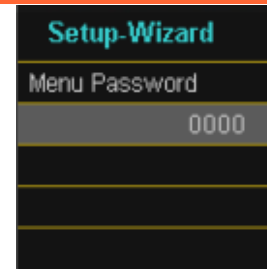

● **Menu Password:**

Input of a 4-digit menu password to lock the device set-up.



This page is only displayed in the active Security Mode.

▶ **Wizard Final Page**

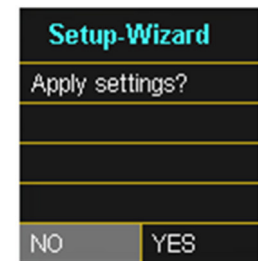

● **Accept settings:**

At this point all settings for the device can be accepted or the setup wizard can be cancelled.

If the wizard is aborted, the wizard will appear again and again each time the device is restarted because the necessary basic settings have not been made.



As of firmware version 2.0, the Start-up wizard can no longer be aborted the first time it is run!

With the confirmation "Yes":

- restarts the device
- the device accepts all changes
- the device deletes all old measurement data in the device memory
- Many parameters are reset to factory settings.

The measurement campaign is started after the restart, all recorders are active.

▶ **Wizard Menu Password**

5. Technical Data

5.1 Dimensions / Weight

Dimensions / Weight	
L x B x H	160 x 90 x 58 mm
Weight	502g

5.2 Electrical safety – environmental parameter

Environmental parameters	Storage and transport	Operation
Ambient temperature : Limit range of operation	IEC 60721-3-1 / 1K5 -40 ... +70°C IEC 60721-3-2 / 2K4 -40 ... +70°C	IEC 61010 H1: -25 ... +45°C H2: -25 ... +50°C H2
Ambient temperature : Rated range of operation H1 Rated range of operation H2	---	IEC DIN EN 61010 -25 ... +45°C -25 ... +50°C
Relative humidity: 24h average No condensation or ice	5...95 %	5...95 %
Solar radiations	---	700 W/m ²
Vibration, earth tremors	IEC 60721-3-1 / 1M1 IEC 60721-3-2 / 2M1	IEC 60721-3-3 / 3M1

5.3 Power supply for PQI-DA smart

Feature	H1	H2
AC Nominal range	100...240 V	-
AC Operating range	90...264 V	-
DC Nominal range]	110...320 V	24...60 V
DC Operating range	100...350 V	18...75 V
Power consumption	≤ 10 W < 20 VA	≤ 10 W
Frequency Nominal	50...60 Hz	DC
Frequency Operating	40...70 Hz	DC
External fuse characteristics	6A B	6A B
Energy storage	2 sec	2 sec

5.4 Voltage Inputs

Voltage inputs		E00
Channels	U ₁ , U ₂ , U ₃ , U _{N/E/4}	
Electrical safety DIN EN 61010	300 V CAT IV 600 V CAT III	
Input reference level	PE	
Impedance -> PE	10 MΩ 25pF	
Nominal input voltage U _n	230 VAC	
Full scale range (FSR)	0...480 VAC L-E	
Waveform	AC & DC, any	
Maximum crest factor @ U _N	3	
Bandwidth	DC...20 kHz	
Nominal power frequency f _N	50 Hz / 60 Hz	
Frequency range of the fundamental	f _N ± 15% 42.5..50..57.5 Hz 51.0..60..69.0 Hz	

5.5 Current Inputs

Current inputs		
Option	C30	C31
Channels	I1, I2, I3, IN/4	
Electrical safety IEC 61010-1:2010	300V CAT III	
Input type	Differential, isolated	
Impedance	≤ 4 mΩ	
Nominal input current I _n	1 A AC / 5 A AC	
Full scale range (FSR)	10 A _{AC}	100 A _{AC}
Overload capacity permanent	20 A	
≤ 10 sec.	100 A	
≤ 1 sec	500 A	
Waveform	AC, any	
Maximum crest factor @ I _n	4	
Bandwidth	25 Hz...20 kHz	

Current inputs (Rogowski coil) – Feature C40

Option	C40
Channels	I1, I2, I3, IN/4
Impedance	1 MΩ
Input range	0.35 V _{AC}
Bandwidth	DC...20 kHz
AC Requirements	galvanic isolated

Current inputs (current clamps)		
Feature	C44	C45
Channels	I1, I2, I3, IN/4	
Impedance	1 MΩ	1 MΩ
Input range	0.5 V _{AC}	4 V _{DC}
Bandwidth	DC...20 kHz	
AC Requirements	galvanic isolated	

5.6 Binary inputs

Binary inputs (BI)	
Range	0 V..250 V _{AC} / V _{DC}
H – Level	> 35 V
L – Level	< 20 V
Signal frequency	DC ... 70 Hz
Input resistance	> 100 kΩ
Electrical isolation	Optocoupler, electrically isolated
Electrical safety DIN EN 61010	300V

5.7 Binary outputs

Binary outputs (BO)	
Contact specification (EN60947-4-1, -5-1) : Configuration	SPDT (Single Pole Double Throw)
Nominal voltage	250 VAC
Nominal current	6 A
Nominal load AC1	1500 VA
Nominal load AC15, 230VAC	300 VA
Interrupting power DC1, 30/110/220 V	6/0.2/0.12 A

Number of switching operations AC1	≥ 60·10 ³ electrical
Electrical Isolation	Isolated from all internal potentials
Electrical safety DIN EN 61010	300V

5.8 Electrical safety

Electrical safety	
IEC 61010-1 IEC 61010-2-030	
Protection class	1
Pollution degree	2
Overvoltage category mains supply option :	
H1	300 V / CAT II
H2	150 V / CAT III
Measurement category	300 V / CAT IV 600 / CAT III
Altitude	≤ 2000m
IP protection class in installed condition	IP54

Electromagnetic Compatibility

Immunity

- IEC 61000-6-5, Environment H

Emissions

- CISPR22 (EN 55022) , Class A

5.9 Connection / terminals

Please observe the safety guidelines and regulations in the chapter "Connection"!

Terminal strip no.	Designation	Function	Ter- minal no.	Cross sec- tion [mm ²]	Stripping length [mm]	
X1	Auxiliary voltage	U _H	L (+)	11	0,75 – 1,5	6
			N (-)	12	0,75 – 1,5	6
X1	Ground	GN D	E	13	1,5 – 2,5	8
X2	Binary input	BI1	+	21	0,75 – 1,5	6
			-	22	0,75 – 1,5	6
		BI2	+	23	0,75 – 1,5	6
			-	24	0,75 – 1,5	6
X3	Phase voltage	U ₁	L1	31	0,75 – 1,5	6
	Phase voltage	U ₂	L2	32	0,75 – 1,5	6
	Phase voltage	U ₃	L3	33	0,75 – 1,5	6
	Neutral point volt- age	U ₄	N	34	0,75 – 1,5	6
X5	Binary output 1	R1	NC	51	0,75 – 1,5	6
			Pol	52	0,75 – 1,5	6
			NO	53	0,75 – 1,5	6
	Binary output 2	R2	NC	54	0,75 – 1,5	6
			Pol	55	0,75 – 1,5	6
			NO	56	0,75 – 1,5	6
X6	Phase current L1	I1	S1	61	1,5 - 4	8
	S2		62			
	Phase current L2	I2	S1	63	1,5 - 4	8
	S2		64			
Phase current L3	I3	S1	65	1,5 - 4	8	
S2		66				
Neutral conductor / sum current	I4	S1	67	1,5 - 4	8	
		S2	68			



Connection cables to be used

- - Provide safety devices (fuse) for CAT II.
- - Do not mix touchable and dangerous active circuits.
- - Connection cables must be designed for a temperature of at least 62°C.

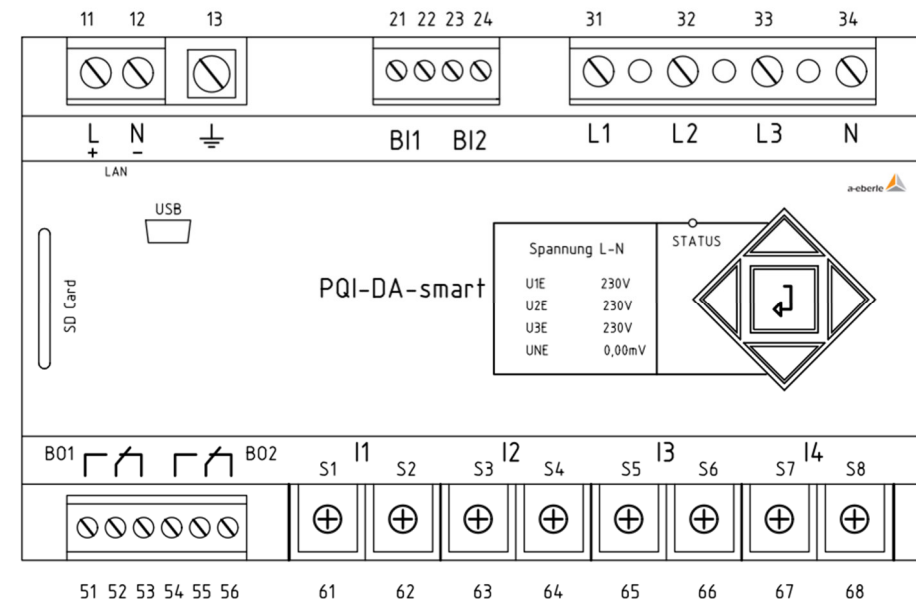

A. Eberle GmbH & Co KG

Frankenstraße 160
D-90461 Nuernberg

Tel.: +49 (0) 911 / 62 81 08-0
Fax: +49 (0) 911 / 62 81 08 99
E-Mail: info@a-eberle.de

<http://www.a-eberle.de>

Nr. 584.0826

Version: 14.04.2020 15:09